



# DSS-330VH/6-1 Vibration Test System

| Shaker Specifications DS330VH                |                      |   |   |
|--|----------------------|---|---|
| Sine (Pk)                                    | 150 kgf (330 lbf)    | Body Suspension Natural Frequency (Thrust Axis) | 3 Hz  |
| Random (RMS)                                 | 150 kgf (330 lbf)    |   |   |
| Shock (Pk)                                   | 300 kgf (660 lbf)    | Table Diameter                                  | 150 mm (5.9" )  |
| Usable Frequency                             | 5 to 4,500 Hz        | Armature Effective Nominal Weight               | 2 kg (4.4 lbs)  |
| Maximum Displacement(p-p)                    | 25mm (1" )           |   |   |
| Maximum Velocity                             | 200 cm/s (78.7 in/s) | Load Attachment Points (Standard)               | 13 stainless steel M8 Inserts (UNC option)              |
| Maximum Acceleration                         | 50 g/75 g            | Stray Flux Density @6 inch (152 mm) above table | < 3 mT (30 gauss),but 1 mT (10 gauss) by special design |
| Fundamental Resonance Frequency (Bare table) | 3,400 Hz (nom.) ± 5% |   |   |
| Vertical Load Support                        | 70 kg (154 lbs)      | Overall Dimensions                              | 694mmL×520mmD×610mmH (27.3" L×20.5" D×24.0" H)          |
|  |                      | Weight of Shaker(Uncrated)                      | 395 kg(869 lbs)   |

| Power Amplifier Specifications SA-1.5   |   | Blower Specifications B-200 |                                      |
|---|---|-----------------------------|--------------------------------------|
| Rated Output Capacity   | 1.5 kVA   | Blower Power (Full Load)    | 0.75 kW (1 HP)(Based on 380VAC,50Hz) |
| Signal to Noise Ratio   | Greater than 65 dB  | Air Flow                    | 0.1 m³/s (212 CFM)                   |
| Amplifier Efficiency  | Greater than 90%  | Air Pressure                | 1 kpa (0.15 PSI)                     |
| Interlock Protection(to prevent the output devices from working outside their specified limits) | <ul style="list-style-type: none"> <li>• Logic Fault</li> <li>• Input Phase Loss</li> <li>• Over-Voltage</li> <li>• Control Power</li> <li>• External Fault</li> <li>• Input Under-Voltage</li> <li>• Over-Temp (Field Coil and Driving Coil)</li> <li>• Over-Current</li> <li>• Air Pressure</li> <li>• Over-Travel</li> </ul> | Air Duct length             | 4m                                   |

| System Environmental Requirement |  | SYSTEM OPTIONS                    |                   |
|----------------------------------|--|-----------------------------------|-------------------|
| Operating Room Temperature       | 0 to 40 degree C   | • Slip Table Configuration        | • Head Expander   |
| Humidity                         | 0 to 90%, non condensing   | • V-Groove Caster and Rail System | • Thermal Barrier |
| Power Supply Requirement         | 380 VAC, 50Hz, 3Ph, 4kVA /4.5 kVA (All kinds of Power supply are optional) |                                   | • Remote Control  |
| Compressed Air Requirement       | 0.6 Mpa (87 psi)   |                                   |                   |

※The standard cable length between Shaker and Power Amplifier is 6m.

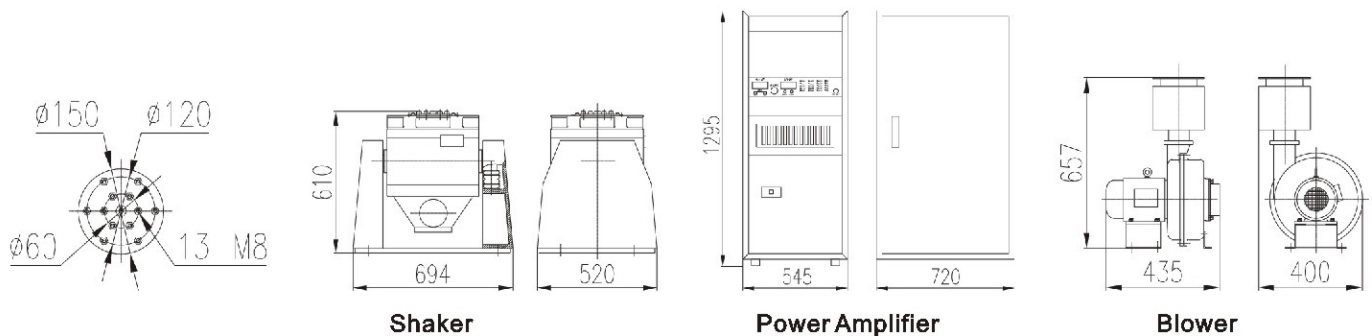

NOTE: In keeping with our commitment to continuous product improvement, the information herein is subject to change.  
 DYNAMIC SOLUTIONS, LLC P.O. BOX 7963, NORTHRIDGE, CA 91327 (PH) 818.831.0832, (F) 818.831.0842  
 WWW.DYNSOLUSA.COM SALES@DYNSOLUSA.COM